

Dell 16 Premium

DA16250

External Display Connection Guide

Notes, cautions, and warnings

 **NOTE:** A NOTE indicates important information that helps you make better use of your product.

 **CAUTION:** A CAUTION indicates either potential damage to hardware or loss of data and tells you how to avoid the problem.

 **WARNING:** A WARNING indicates a potential for property damage, personal injury, or death.

Contents

Chapter 1: Before you begin	4
Check the graphics options on your computer.....	4
Modes of connection.....	4
Turn off the computer display.....	5
Chapter 2: Connect external displays	6
Connecting to an external display.....	6
Connecting to multiple displays.....	8
Chapter 3: Troubleshooting	11
Chapter 4: Getting help and contacting Dell Technologies	12
Chapter 5: Revision history	13

Before you begin

Before you begin, ensure that you:

- Check the [graphics options on your computer](#).
- Check the ports available on your external displays and decide on the [mode of connection](#).

Check the graphics options on your computer

The number of external displays that are supported depends on the type of graphics card available on your computer.

For more information about the graphic card available on your computer, run **Dell SupportAssist** on your computer, or scan your hardware at the [Dell Support site](#).

Your computer may be installed with one of these graphic options:

- Integrated graphics only: Intel Arc 140T Graphics

NOTE: Requires 128-bit (2-channel) memory populated.

- Integrated graphics with discrete graphics: Intel Arc 140T Graphics with NVIDIA GeForce RTX 5050, 5060, or 5070

Modes of connection

Depending on the connectors available on your external display, you can connect the display to the USB-C ports on your computer using:

- Thunderbolt 4 or Thunderbolt 5 cables, adapters, or docking stations
- USB-C cables, adapters, or docking stations

NOTE: To experience the full resolution supported by your external displays, use appropriate cables. For example, use DisplayPort or HDMI cables for 4K and above resolution.

NOTE: USB-C or Thunderbolt docking stations can be used to connect external displays to the computer using a single USB-C cable, while charging the computer. For more information about the types of docking stations available from Dell, search for *Guide to Dell Docking Stations* at the Knowledge Base Resource at the [Dell Support site](#).

NOTE: USB-C adapters can also be used to connect external displays to the computer, though these do not allow power charging simultaneously. For more information about the types of USB-C adapters available from Dell, search for *Thunderbolt USB-C Adapters and Cables* at the Knowledge Base Resource at the [Dell Support site](#).

The USB-C ports available on your computer are shown in the following image.

NOTE: When connecting a display indirectly using an adapter or docking station, it is recommended that you connect the display to the docking station first, then connect the docking station to the USB-C port on your computer.

NOTE: The devices connected to the ports on the left side of the computer have priority over the ports on the right. While connecting external displays, it is recommended that you connect the displays to the left ports.

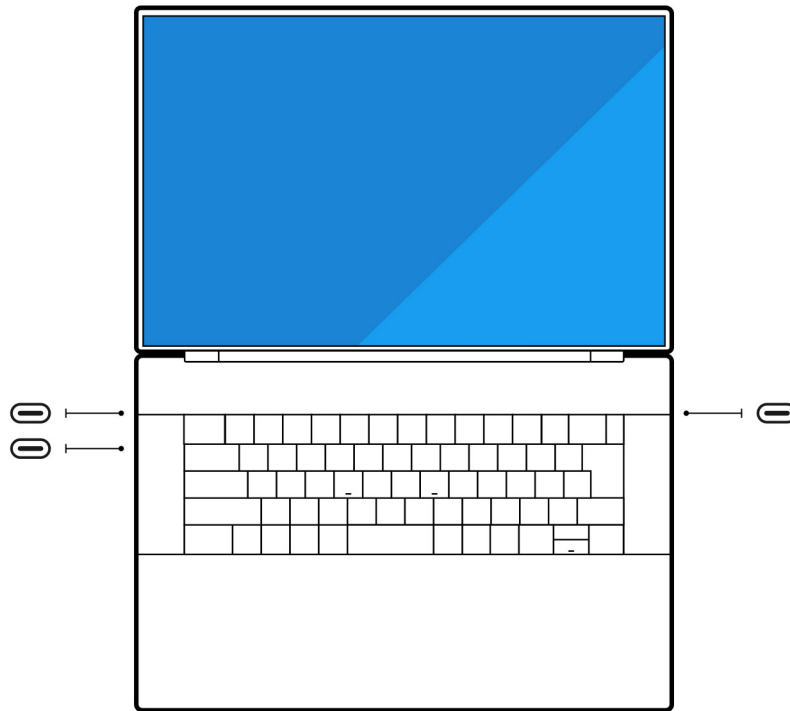

Figure 1. Location of USB-C ports

Turn off the computer display

There are instances in which you may want to turn off the internal display of your computer to connect more external displays. You can turn off the display by using the **Intel HD Graphics Command Center**.

To turn off the computer display:

1. In the Windows search bar, type **Intel Graphics Command Center** and press **Enter**.
2. Accept the **Intel Graphics Command Center** software license agreement.
3. On the **Intel Graphics Command Center** window, click **Display**. The active displays are listed under the **Connected Displays** section.
4. Click the ellipsis (...) in the upper right corner of your primary display, then click **Extend > Display 2**.
5. Click the ellipsis (...) in the upper right corner of display 2, then click **Make Display Primary**.
6. Click the ellipsis (...) in the upper right corner of your computer display, then click **Disable**.

Connect external displays

You can connect up to three 4K external displays to your computer (with the computer internal display turned on) or up to four 4K external displays (with the computer internal display turned off).

NOTE: When you connect a display indirectly using a docking station, it is recommended that you connect the display to the docking station first, before connecting the docking station to the USB-C port on your computer.

NOTE: The USB-C ports on the left side of the computer have priority over the USB-C port on the right side of the computer. It is recommended to connect external displays to the USB-C ports on the left side of the computer first.

The number of displays supported depends on the following:

- If the computer internal display is turned on or off.
- Your docking station may also limit the number of external displays supported. Check the documentation for your docking station for details.

The following table summarizes the number of external displays supported:

Table 1. Display support (up to 4K/60 Hz)

Graphics card	Supported external displays with computer internal display on	Supported external displays with computer internal display off
Intel Arc 140T Graphics (Integrated graphics)	Three	Four
Intel Arc Graphics with NVIDIA GeForce RTX 5050, 5060, or 5070	Three	Four

Table 2. Display support (up to 8K/60 Hz)

Graphics card	Supported external displays with computer internal display on	Supported external displays with computer internal display off
Intel Arc 140T Graphics (Integrated graphics)	One	One
Intel Arc Graphics with NVIDIA GeForce RTX 5050, 5060, or 5070	One	One

The following table shows the supported accessories for connecting external displays to your computer.

Table 3. Supported accessories for connecting external displays

Accessories
Dell Thunderbolt Dock - WD22TB4
Dell Adapter - USB-C to HDMI/DisplayPort with Power Pass-Through
Supplied USB Type-C to USB Type A and DisplayPort dongle to connect to a DisplayPort device

Connecting to an external display

You can connect an external display directly to one of the USB-C ports on your computer, an adapter, or a docking station.

NOTE: If you intend to project only to the external display, connect and configure at least one external display before disabling the computer internal display. For more information, see [Turn off the computer display](#).

- Connect an external display directly using a USB-C or Thunderbolt cable.

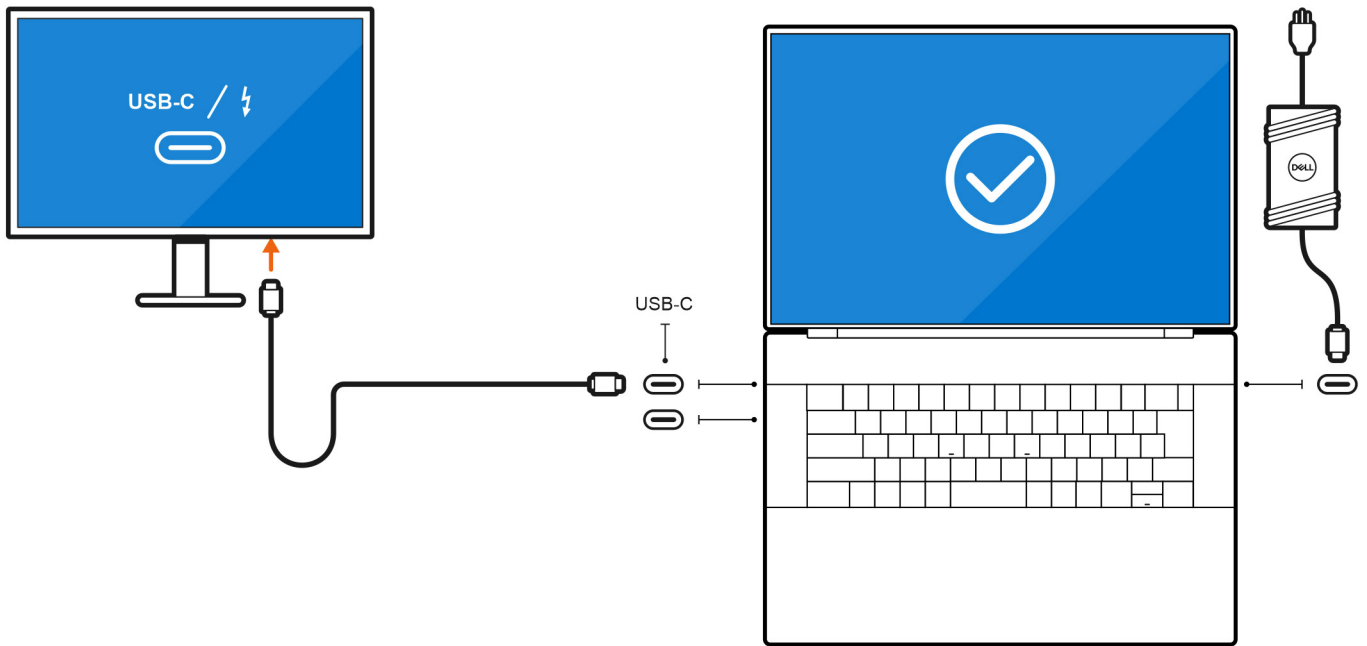

Figure 2. Connect an external display directly using a USB-C or Thunderbolt cable

- Connect an external display using a USB-C cable to Thunderbolt, HDMI, or DisplayPort adapter.

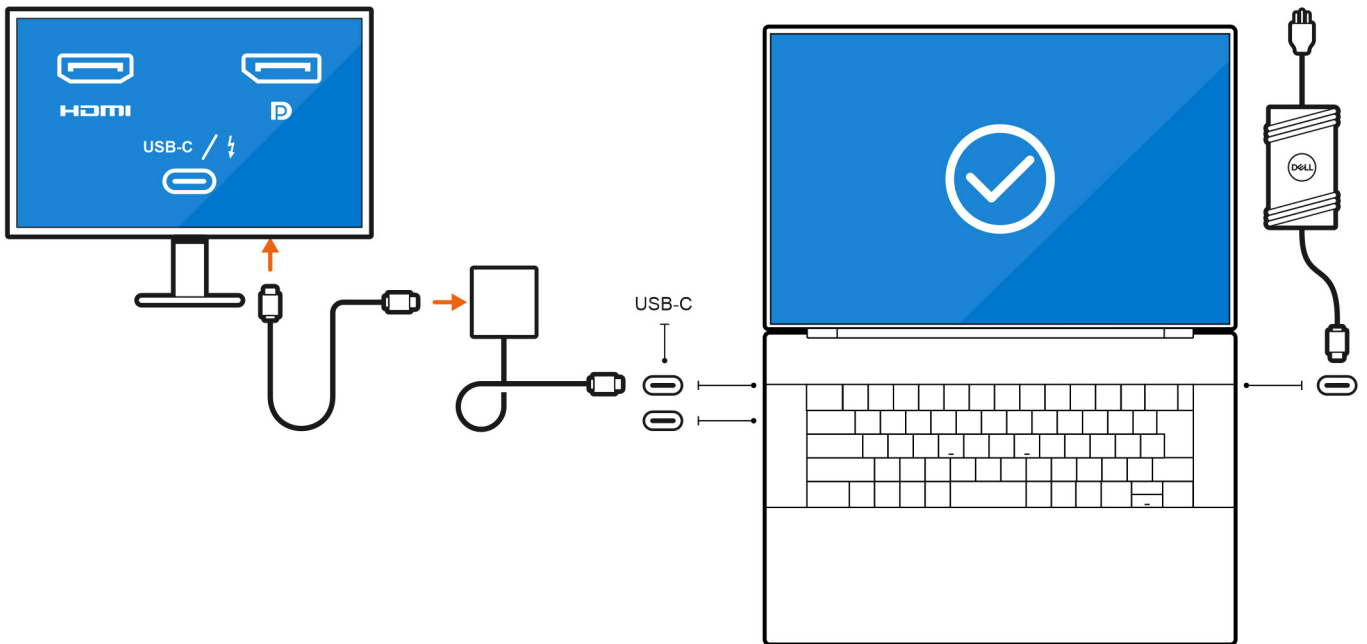

Figure 3. Connect an external display using a USB-C cable to Thunderbolt, HDMI, or DisplayPort adapter

- Connect an external display using a USB-C cable to connect to a docking station.

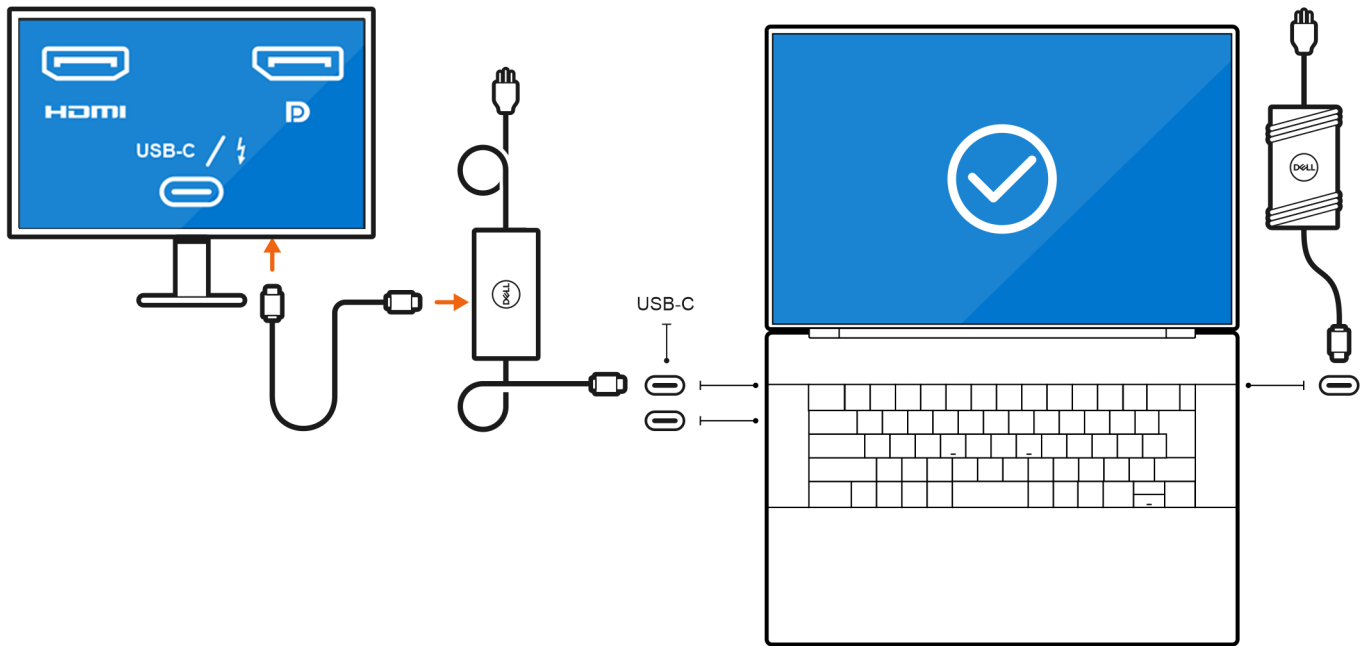

Figure 4. Connect an external display to a docking station using a USB-C cable

Connecting to multiple displays

You can connect up to three 4K external displays to your computer (with the computer internal display turned on) or up to four 4K external displays (with the computer internal display turned off).

- NOTE:** When you connect a display indirectly using a docking station, it is recommended that you connect the display to the docking station first, before connecting the docking station to the USB-C port on your computer.
- NOTE:** The USB-C ports on the left side of the computer have priority over the USB-C port on the right side of the computer. It is recommended to connect external displays to the USB-C ports on the left side of the computer first.

Connect up to three external displays

Connect two external displays using a docking station and one external display directly to the USB-C ports on the computer.

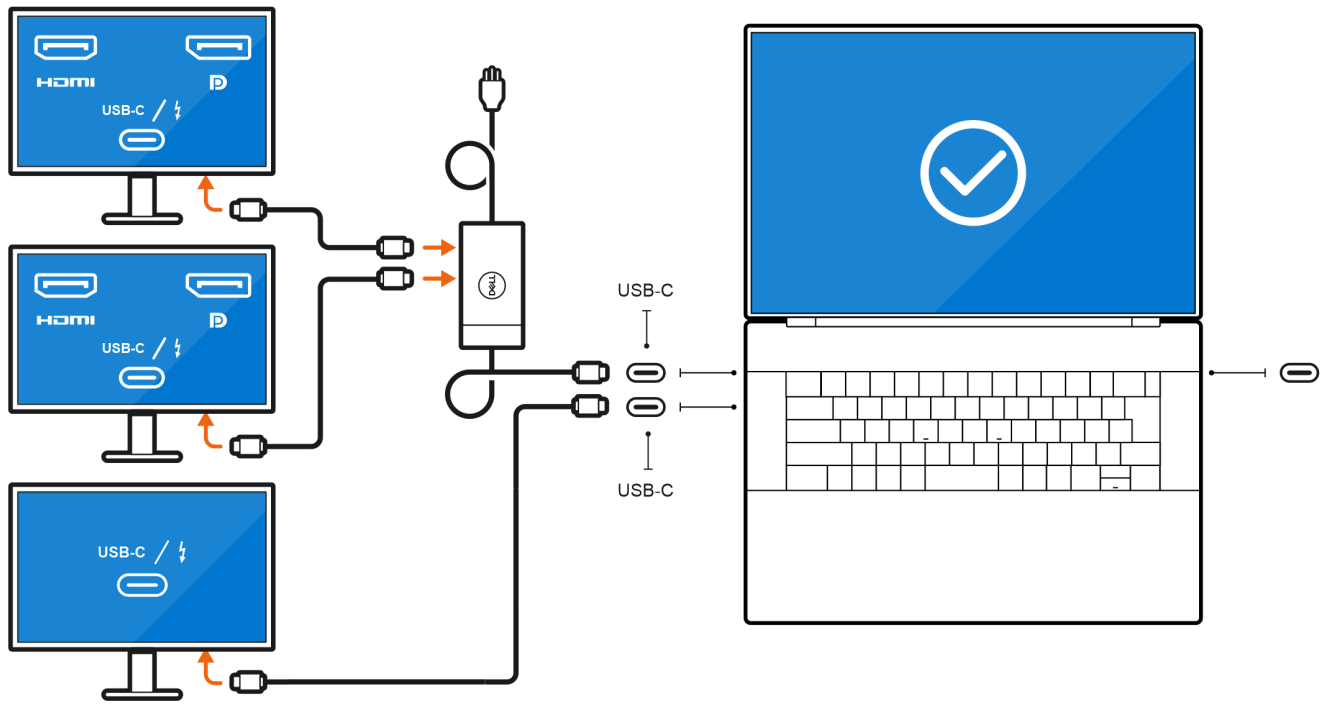

Figure 5. Connect two external displays using a docking station and one external display directly to the USB-C ports on the computer

Connect up to four external displays

- Connect two external displays using a docking station and two more external displays directly to the USB-C ports on the computer.

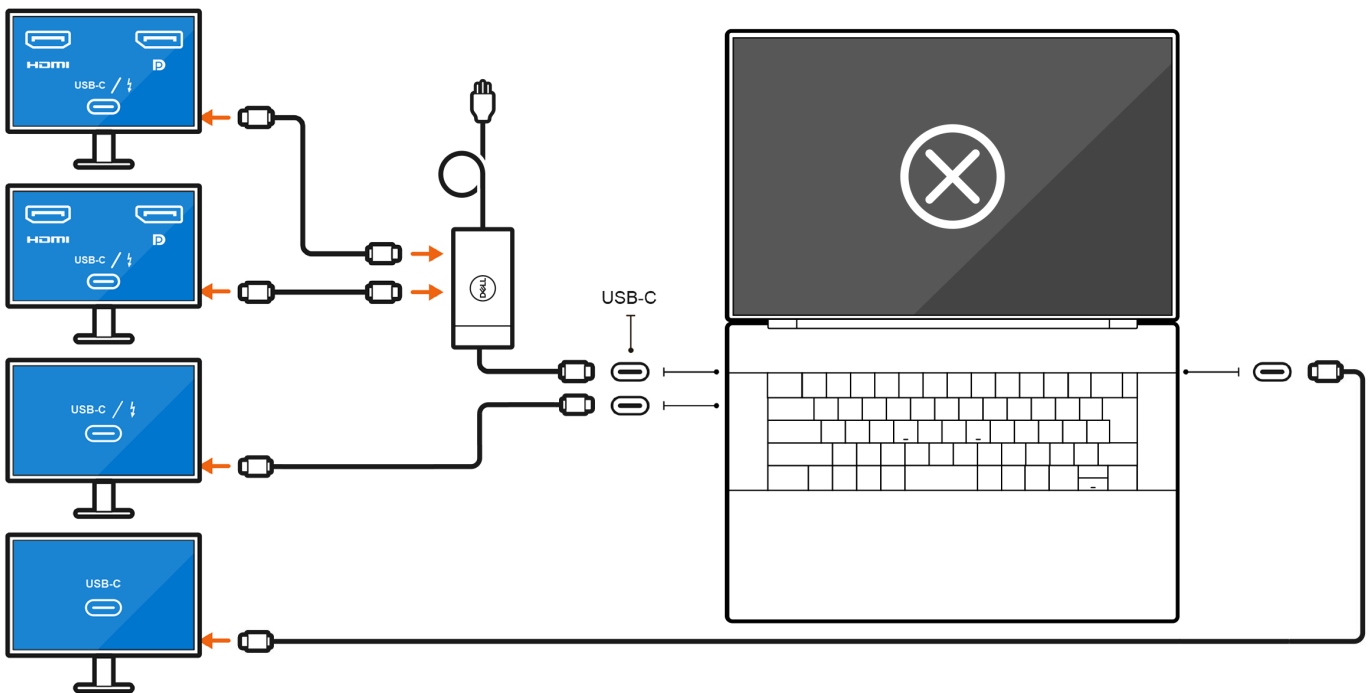

Figure 6. Connect two external displays using a docking station and two more external displays directly to the USB-C ports on the computer

- Connect two external displays using a docking station and two more external displays directly to the USB-C ports on the computer.

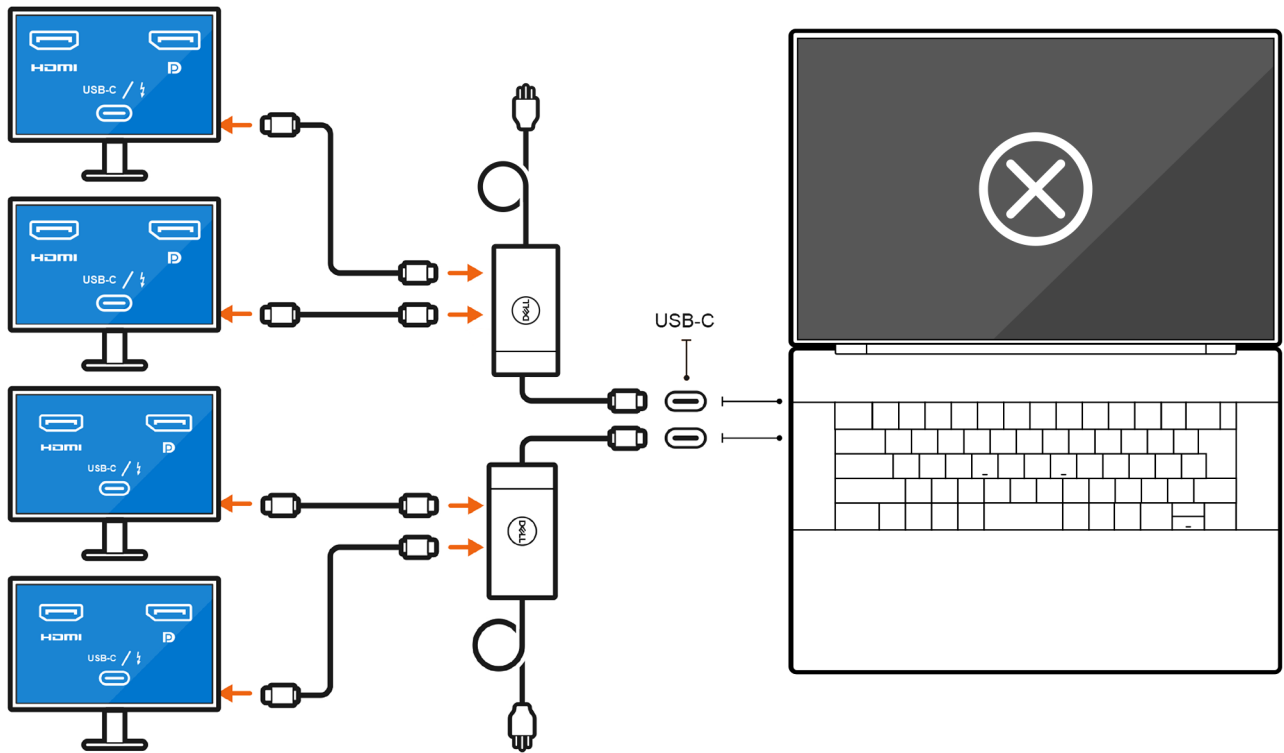

Figure 7. Connect four external displays using two docking stations

Troubleshooting

8K displays cannot select 8K@60 Hz

Question

When I connect an 8K display to the computer using a Thunderbolt or USB Type-C cable directly, the display output only runs 8K@30 Hz.

Cause

There is a hardware limitation (HDMI 8K@60 Hz requires VESA DSC 1.2a PCON IC support which is not supported on the computer).

Workaround

The computer is working as designed.

The display output resolution cannot reach 4K@60 Hz while connecting the display monitor with a HDMI-to-DP or DP-to-HDMI dongle from the docking station to the computer

Question

When I connect a display monitor to the computer using an HDMI-to-DP or DP-to-HDMI dongle from a Dell WD19/WD22 Thunderbolt docking station, the display output resolution cannot reach 4K@60 Hz (only 4K@30 Hz).

Cause

There is a hardware limitation for connection via dongles to the Dell WD19/WD22 (Limited Graphic bandwidth) Thunderbolt docking station.

Workaround

Connect the monitor directly to the HDMI or DP ports on the Thunderbolt docking station.

Getting help and contacting Dell Technologies

Self-help resources

You can get information and help on Dell Technologies products and services using these self-help resources:

Table 4. Self-help resources

Self-help resources	Resource location
Information about Dell Technologies products and services	Dell Site
Contact Support	In Windows search, type <code>Contact Support</code> , and press Enter.
Online help for operating system	Windows Support Site
Access top solutions, diagnostics, drivers and downloads, and learn more about your computer through videos, manuals, and documents.	Your Dell Technologies computer is uniquely identified using a Service Tag or Express Service Code. To view relevant support resources for your Dell Technologies computer, enter the Service Tag or Express Service Code at Dell Support Site . For more information about how to find the Service Tag for your computer, see Instructions on how to find your Service Tag or Serial Number .
Dell Technologies knowledge base articles	<ol style="list-style-type: none"> 1. Go to Dell Support Site. 2. On the menu bar at the top of the Support page, select Support > Support Library. 3. In the Search field on the Support Library page, type the keyword, topic, or model number, and then click or tap the search icon to view the related articles.

Contacting Dell Technologies

To contact Dell Technologies for sales, technical support, or customer service issues, see [Contact Support at Dell Support Site](#).

 **NOTE:** Availability of the services may vary depending on the country or region, and product.

 **NOTE:** If you do not have an active Internet connection, you can find contact information about your purchase invoice, packing slip, bill, or Dell Technologies product catalog.

Revision history

Tracks all updates that are made to the document. It typically includes the date of change, version number, and a brief description of the modification. This log helps maintain transparency, accountability, and a clear timeline of progress.

Table 5. Revision history

Revision	Date	Description
A00	07-15-2025	Original publish date.